

# 5. Schematic Diagrams

## 5-1 Main Power

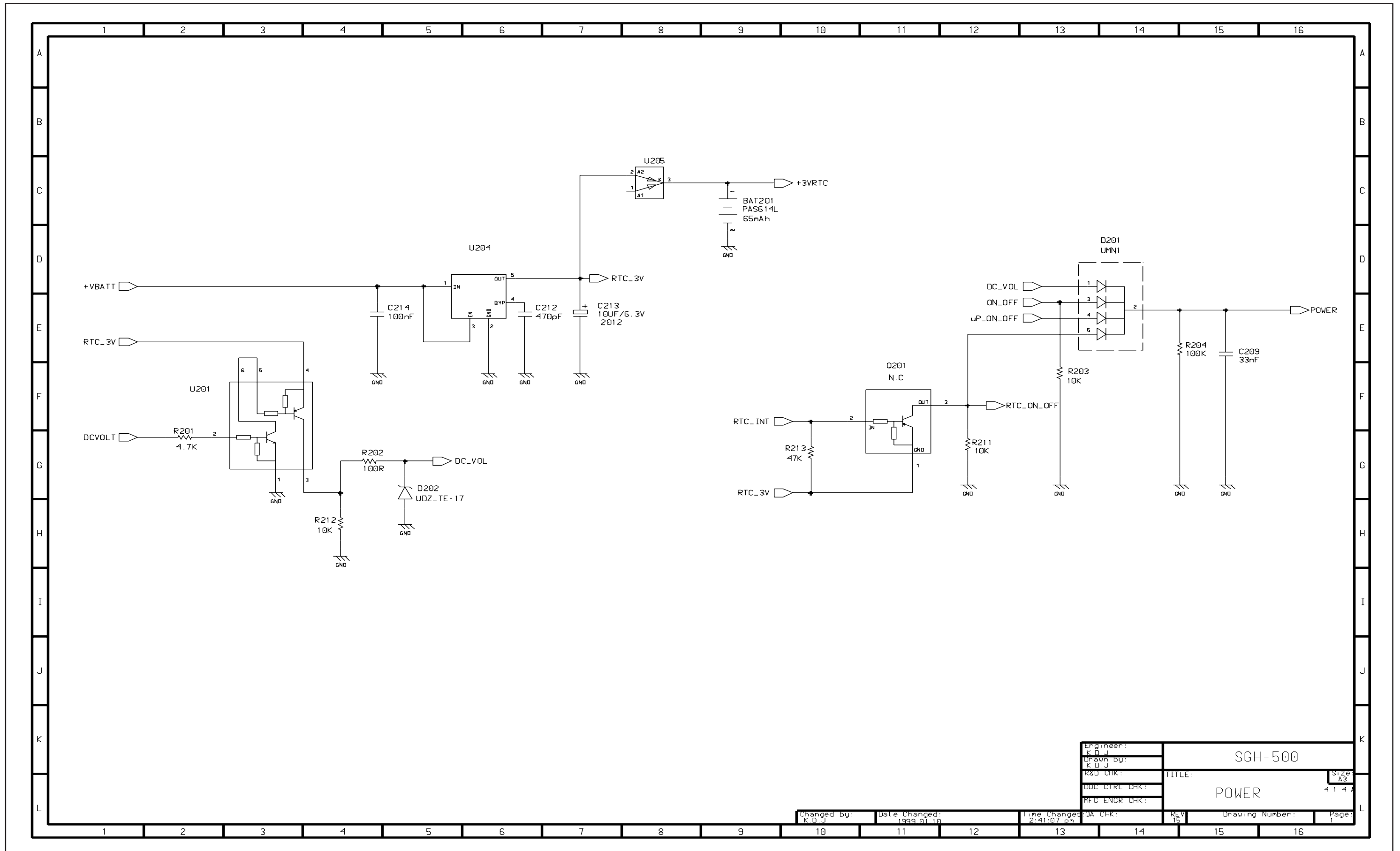

Engineer:	K.D.J.	SGH-500	Size A3
Drawn by:	K.D.J.		
R&D CHK:		TITLE:	41.4.4
DDC CTRL CHK:		POWER	
MFG ENGR CHK:		REV:	15
Changed by:	Date Changed:	Time Changed:	Page:
K.D.J.	1999.01.10	2:41:07 pm	1
QA CHK:		Drawing Number:	

5-2 Memory Power

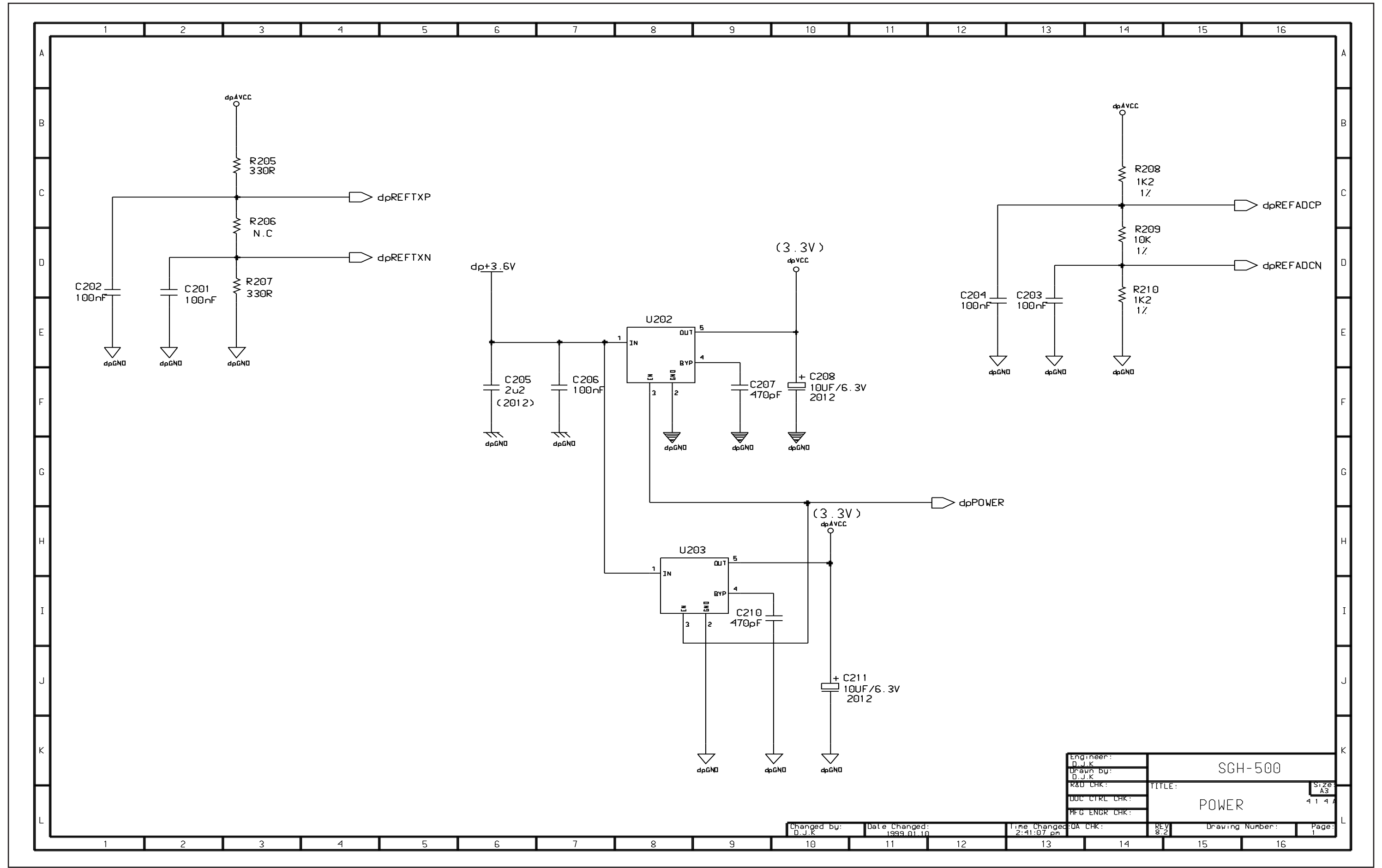

Engineer:	D.J.K.	SGH-500	Size: A3
Drawn by:	D.J.K.		
R&D CHK:			
DOC CTRL CHK:			
MF'G ENGR CHK:		TITLE:	POWER
QA CHK:		REV:	8.2
Changed by:	D.J.K.	Date Changed:	1999.01.10
Time Changed:	2:41:07 pm	Drawing Number:	
Page:	1		

5-3 Charger

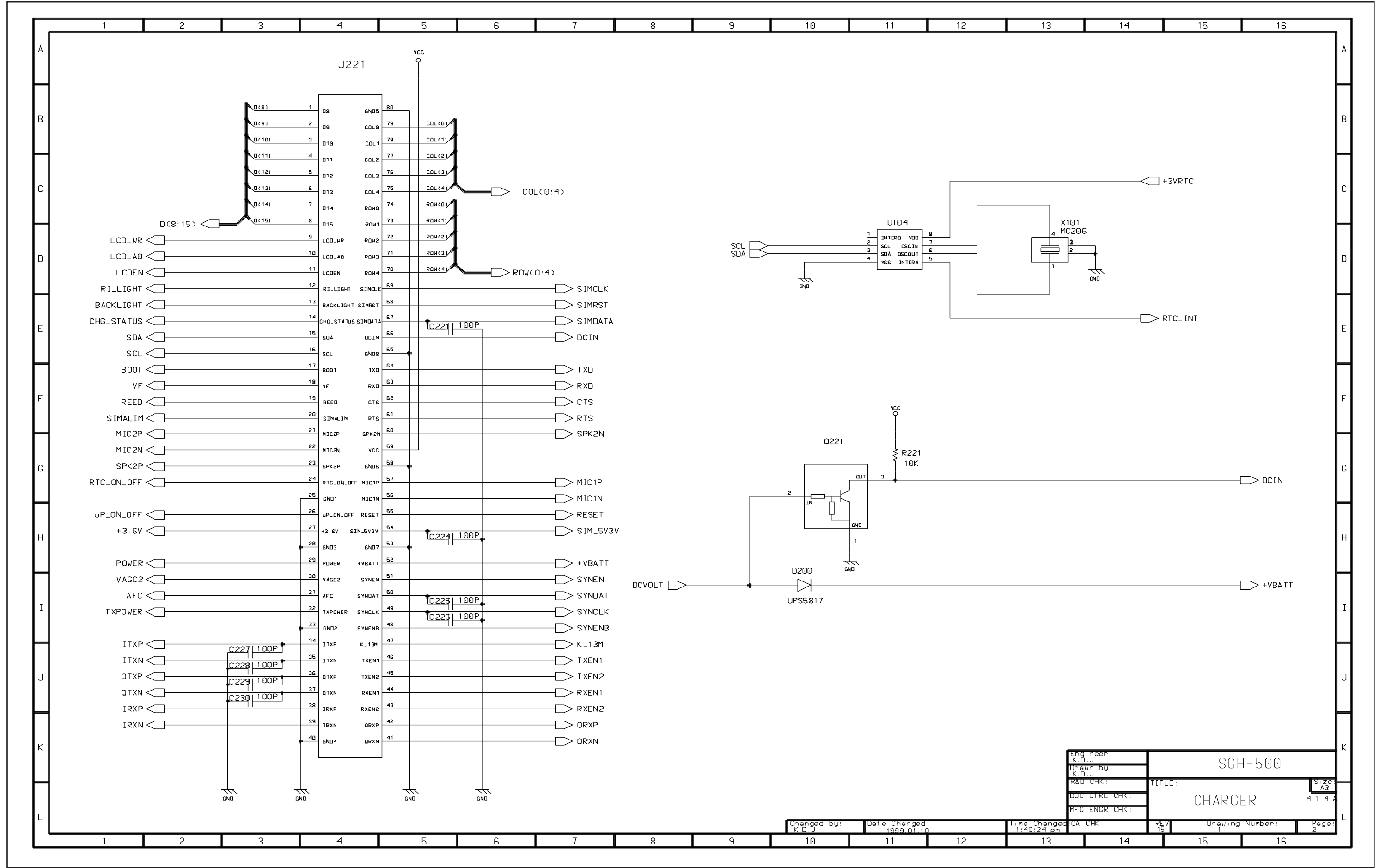

Engineer:	K.D.J	SGH-500	Size A3
Drawn by:	K.D.J		
R&D CHK:		TITLE:	4 1 4 4
DOC CTRL CHK:		CHARGER	
MFG ENGR CHK:			

Changed by:	Date Changed:	Time Changed:	Rev:	Drawing Number:	Page:
K.D.J	1999.01.10	1:40:24 pm	15	1	2

5-4 DC/DC Converter

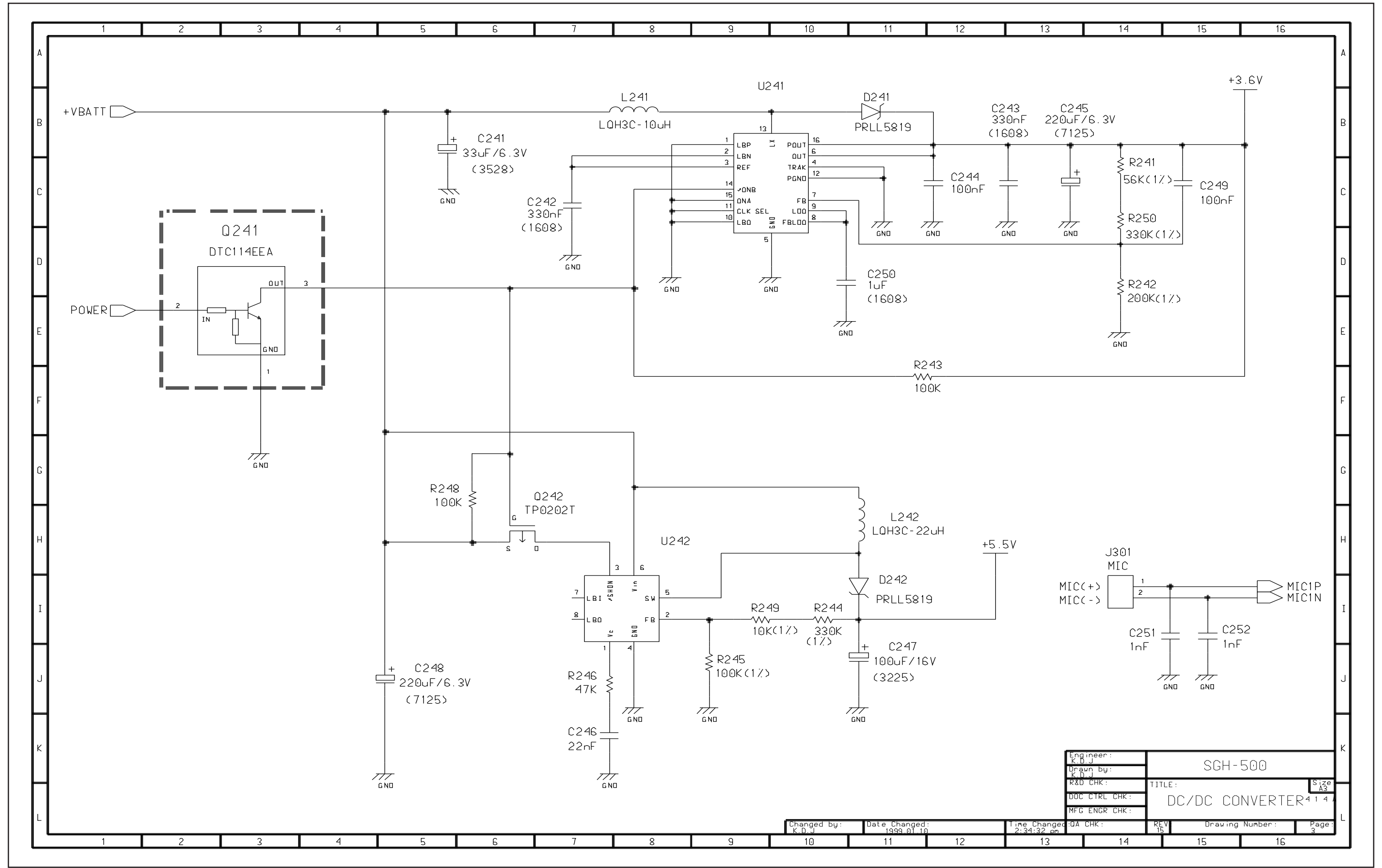

Engineer:	K.D.J.	
Drawn by:	K.D.J.	
R&D CHK:		
DOC CTRL CHK:		
MFG ENGR CHK:		
TITLE:		Size
DC/DC CONVERTER		A3

Changed by:	Date Changed:	Time Changed:	DA CHK:	REV	Drawing Number:	Page:
K.D.J.	1999.01.10	2:34:32 pm		15		3



5-6 Vocoder

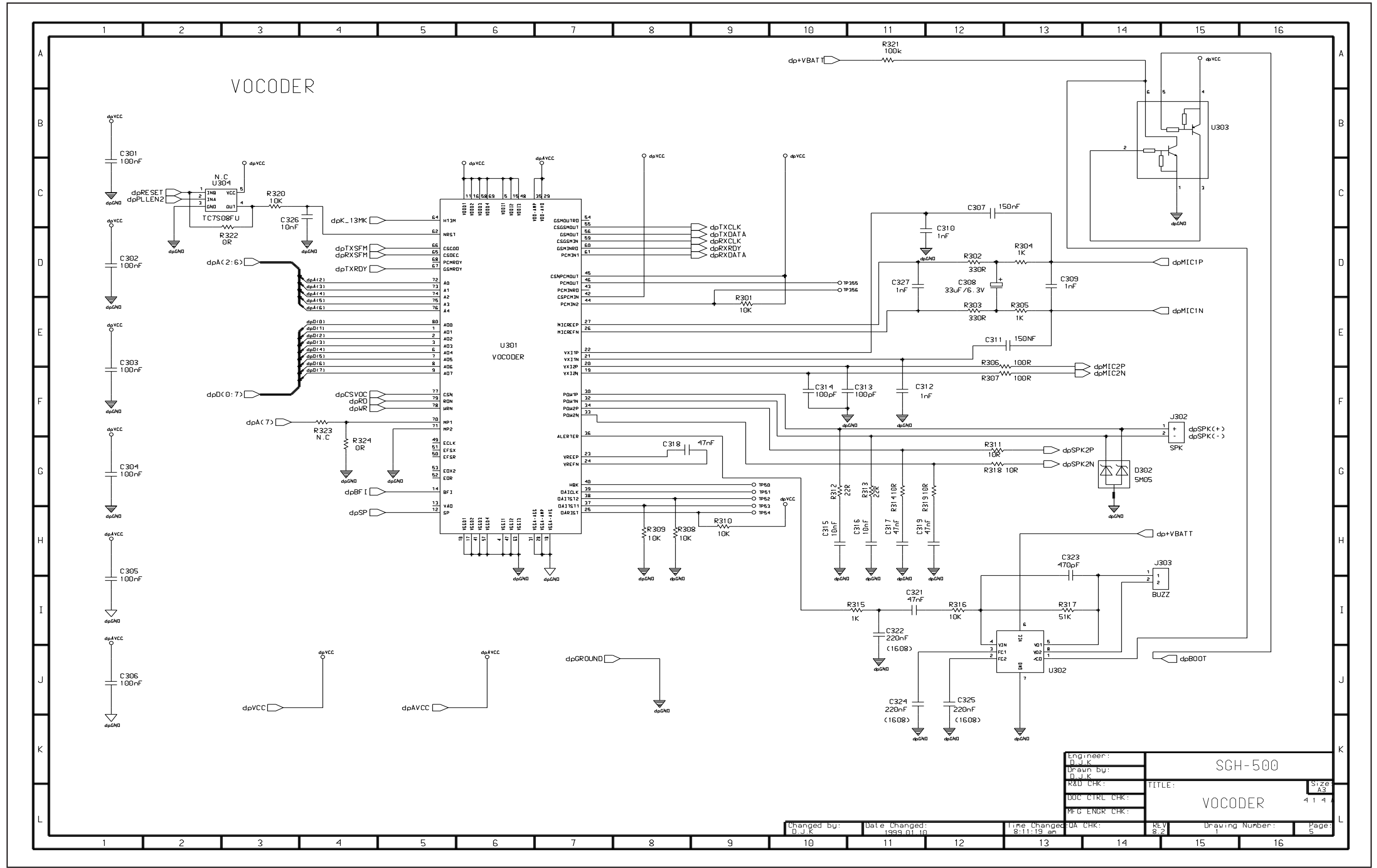

Engineer:	D.J.K.	SGH-500	Size A3
Drawn by:	D.J.K.		
R&D CHK:		TITLE:	VOCODER
DOC CTRL CHK:		REV:	8.2
MFG ENGR CHK:		Drawing Number:	1

Changed by:	D.J.K.	Date Changed:	1999.01.10	Time Changed:	8:11:19 am	FOA CHK:		Page:	5
-------------	--------	---------------	------------	---------------	------------	----------	--	-------	---

5-7 SIM Interface

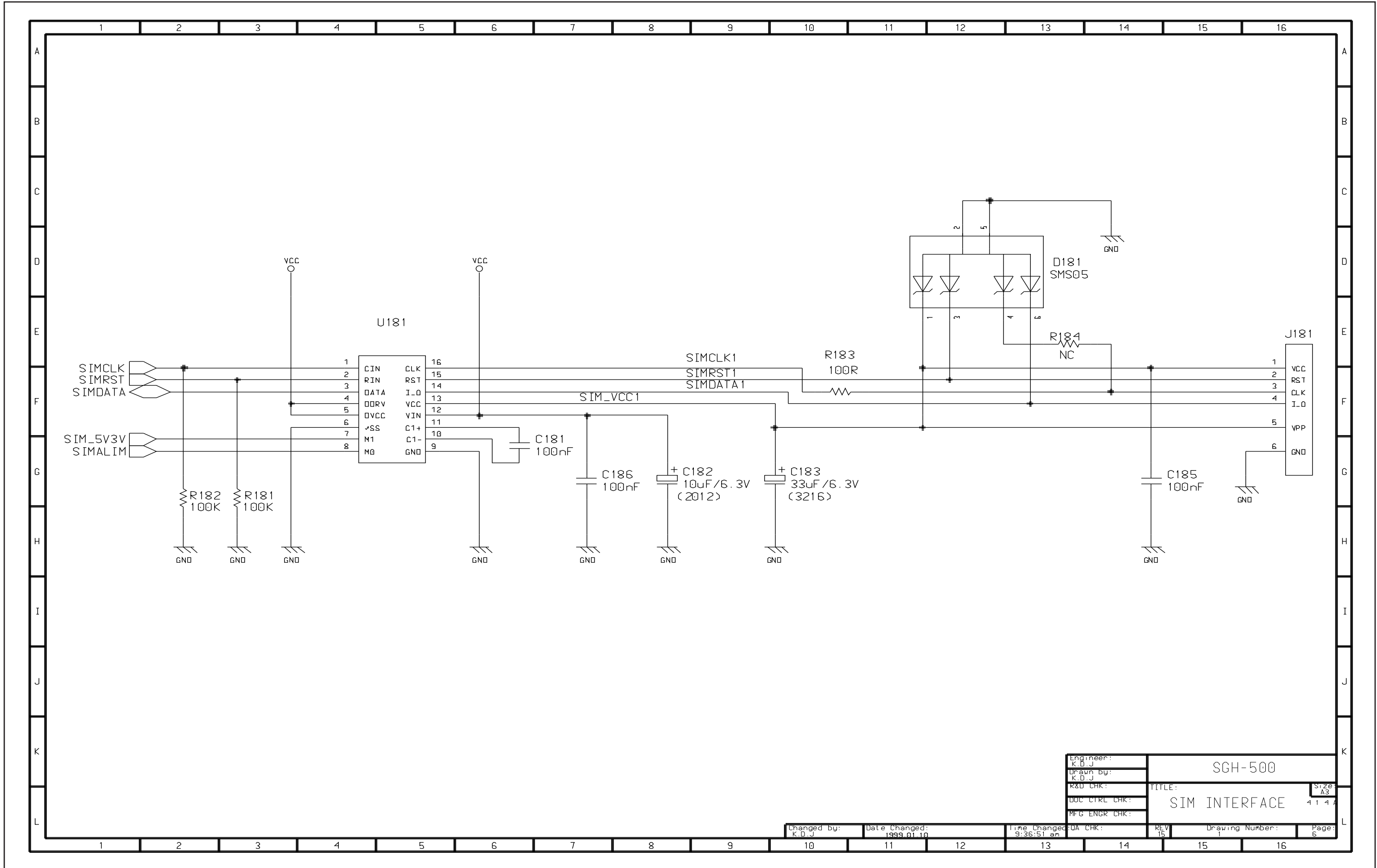

Engineer: K.D.J	SGH-500 TITLE: SIM INTERFACE Size: A3 4 1 4 A				
Drawn by: K.D.J					
R&D CHK:					
DOC CTRL CHK:					
MFG ENGR CHK:					
Changed by: K.D.J	Date Changed: 1999.01.10	Time Changed: 9:36:51 am	REV 15	Drawing Number: 1	Page: 6

5-8 Interface

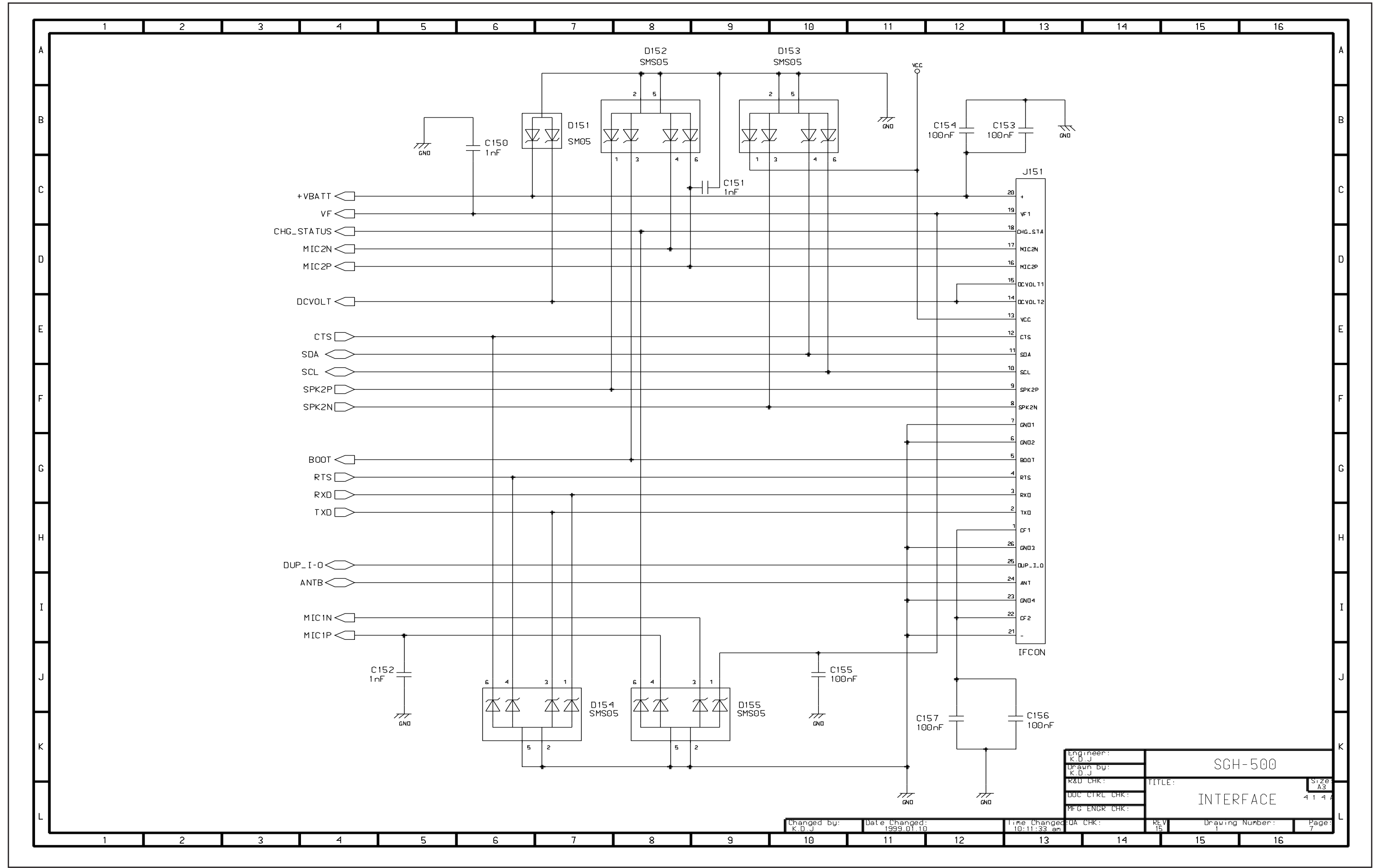

Engineer:	K.O.J		SGH-500	Size A3
Drawn by:	K.O.J			
R&D CHK:			TITLE:	41 4 4
DOC CTRL CHK:			INTERFACE	
MFG ENGR CHK:			REV	Page:
QA CHK:			15	7
Changed by:	Date Changed:	Time Changed:	Drawing Number:	
K.O.J	1999.01.10	10:11:33 am	1	



5-9 LCD & Key (China)

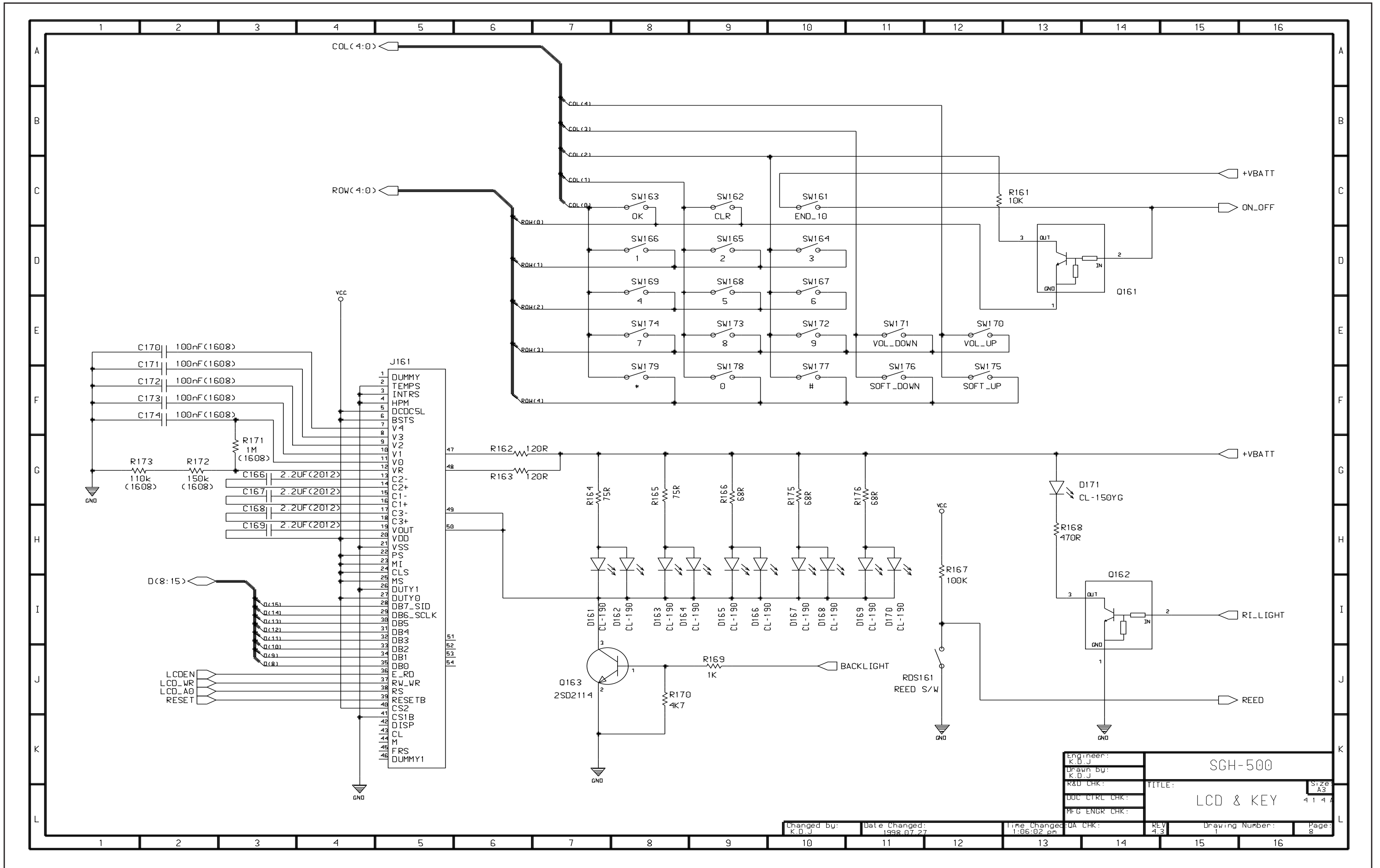

Engineer:	K.D.J	SGH-500	Size A3
Drawn by:	K.D.J		
R&D CHK:		TITLE:	LCD & KEY
DOC CTRL CHK:		REV:	4.3
MFG ENGR CHK:		Drawing Number:	1
QA CHK:		Page:	8

Changed by:	Date Changed:	Time Changed:	Rev:
K.D.J	1998.07.27	1:06:02 pm	4.3

5-10 LCD & Key (Europe)

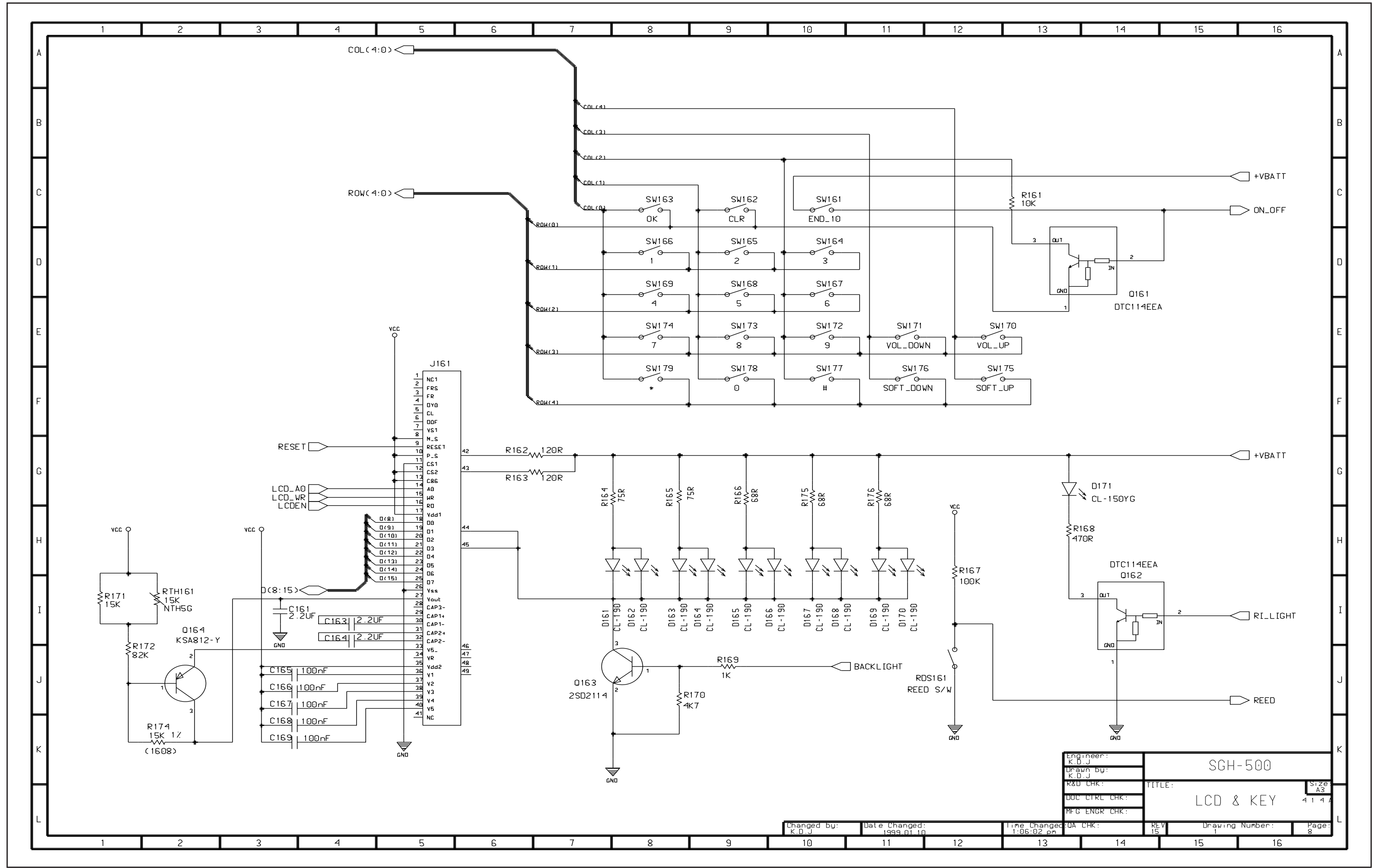

Engineer:	K.D.J	SGH-500 LCD & KEY Size A3 4147
Drawn by:	K.D.J	
R&D CHK:		
DOC CTRL CHK:		
MFG ENGR CHK:		

Changed by:	Date Changed:	Time Changed:	QA CHK:	REV:	Drawing Number:	Page:
K.D.J	1999.01.10	1:06:02 pm		15	1	8

5-11 Power & 13 MHz TCXO

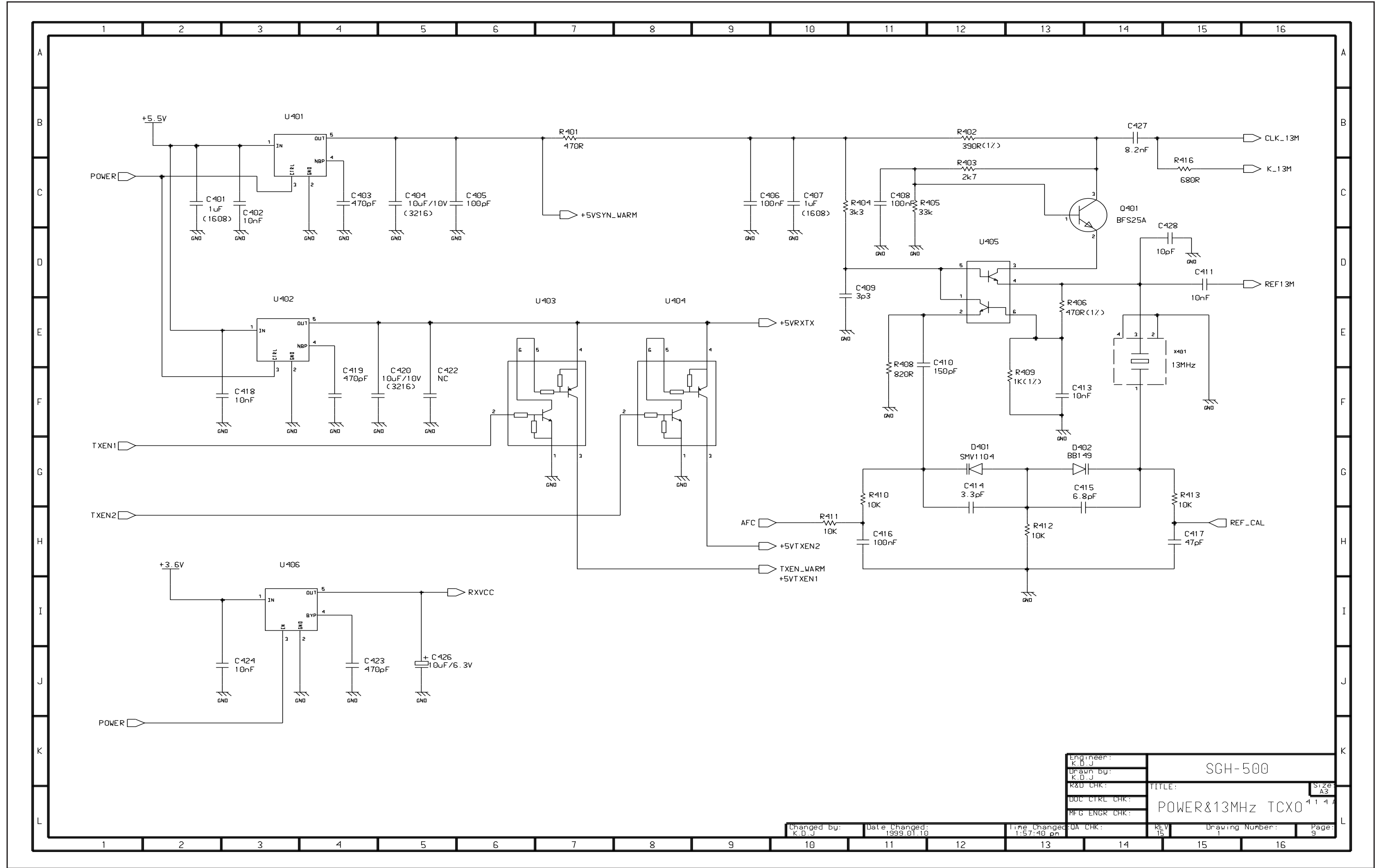

Engineer:	K.D.J	TITLE: SGH-500 POWER&13MHz TCXO	Size:	A3
Drawn by:	K.D.J		Doc Ctrl Chk:	
R&D Chk:			Mfg Engr Chk:	
Doc Ctrl Chk:			FOA Chk:	
Mfg Engr Chk:			REV:	1
Changed by: K.D.J Date Changed: 1999.01.10 Time Changed: 1:57:40 pm		Drawing Number: 1 Page: 9		

5-12 AD607 & BB Filter

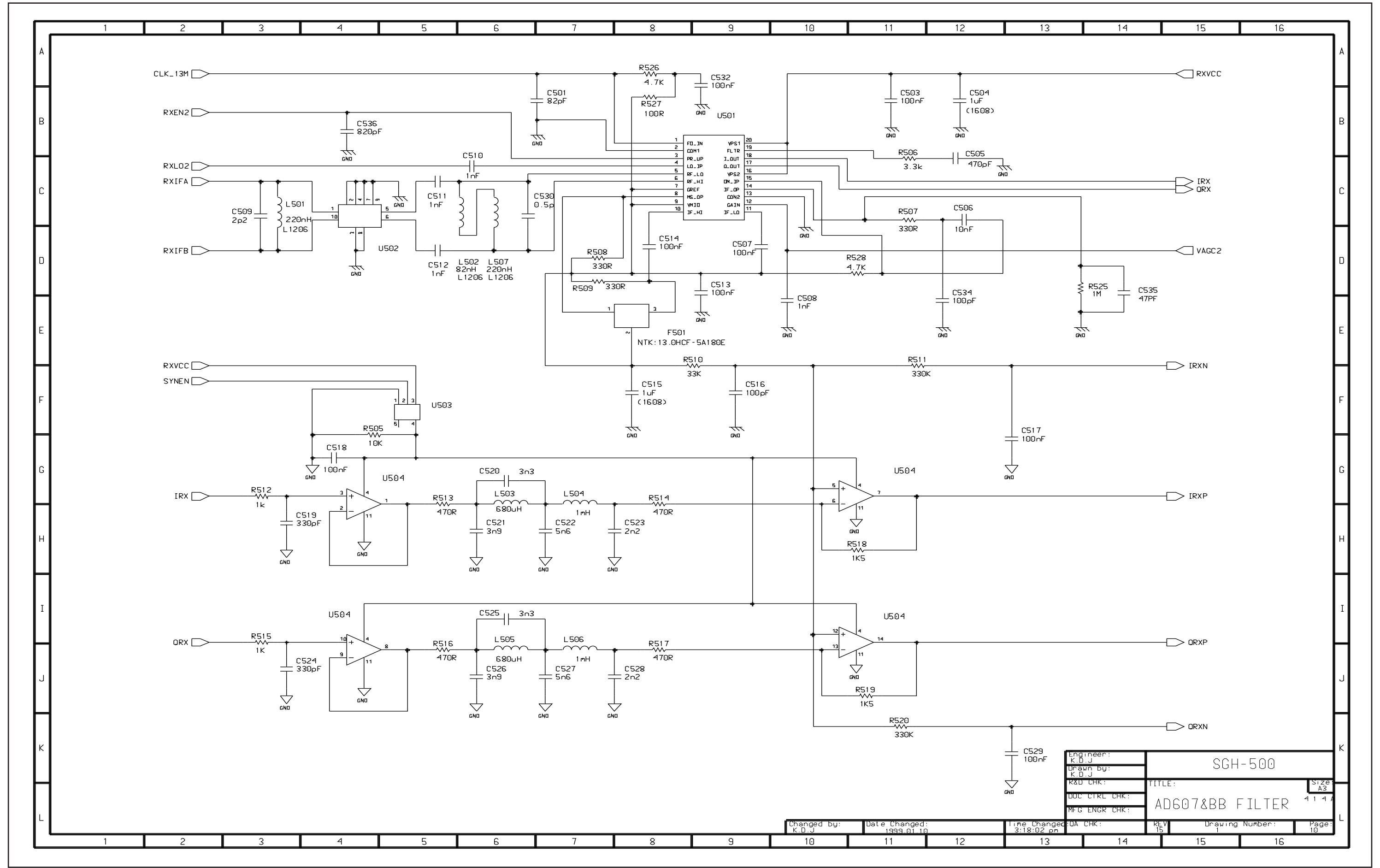

5-13 Synthesizer

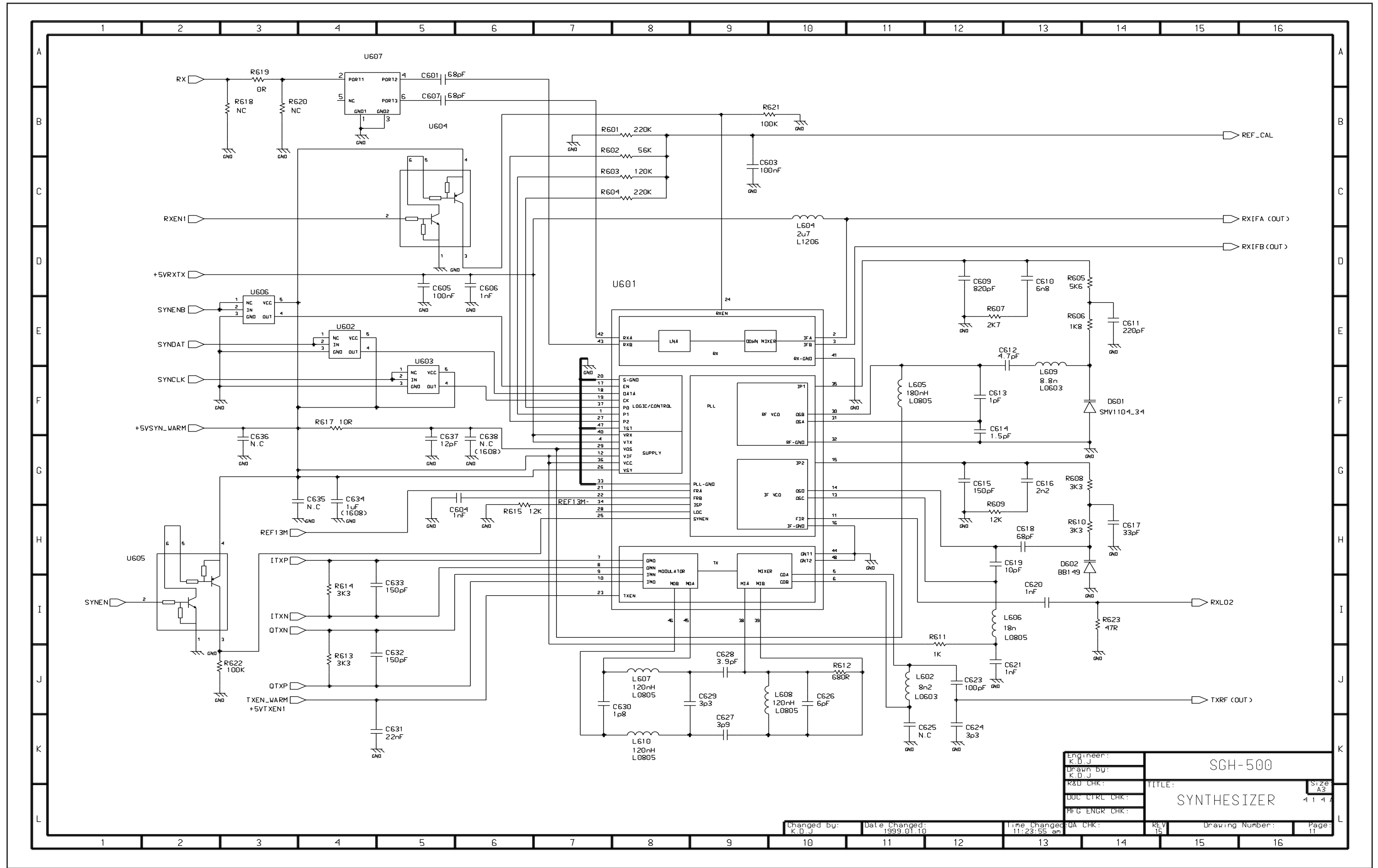

Engineer:	K.D.J.	SGH-500 TITLE: SYNTHESIZER Size A3 4147
Drawn by:	K.D.J.	
R&D CHK:		
DOC CTRL CHK:		
MFG ENGR CHK:		

Changed by:	Date Changed:	Time Changed:	QA CHK:	REV:	Drawing Number:	Page:
K.D.J.	1999.01.10	11:23:55 am		15		11

5-14 Transmitter

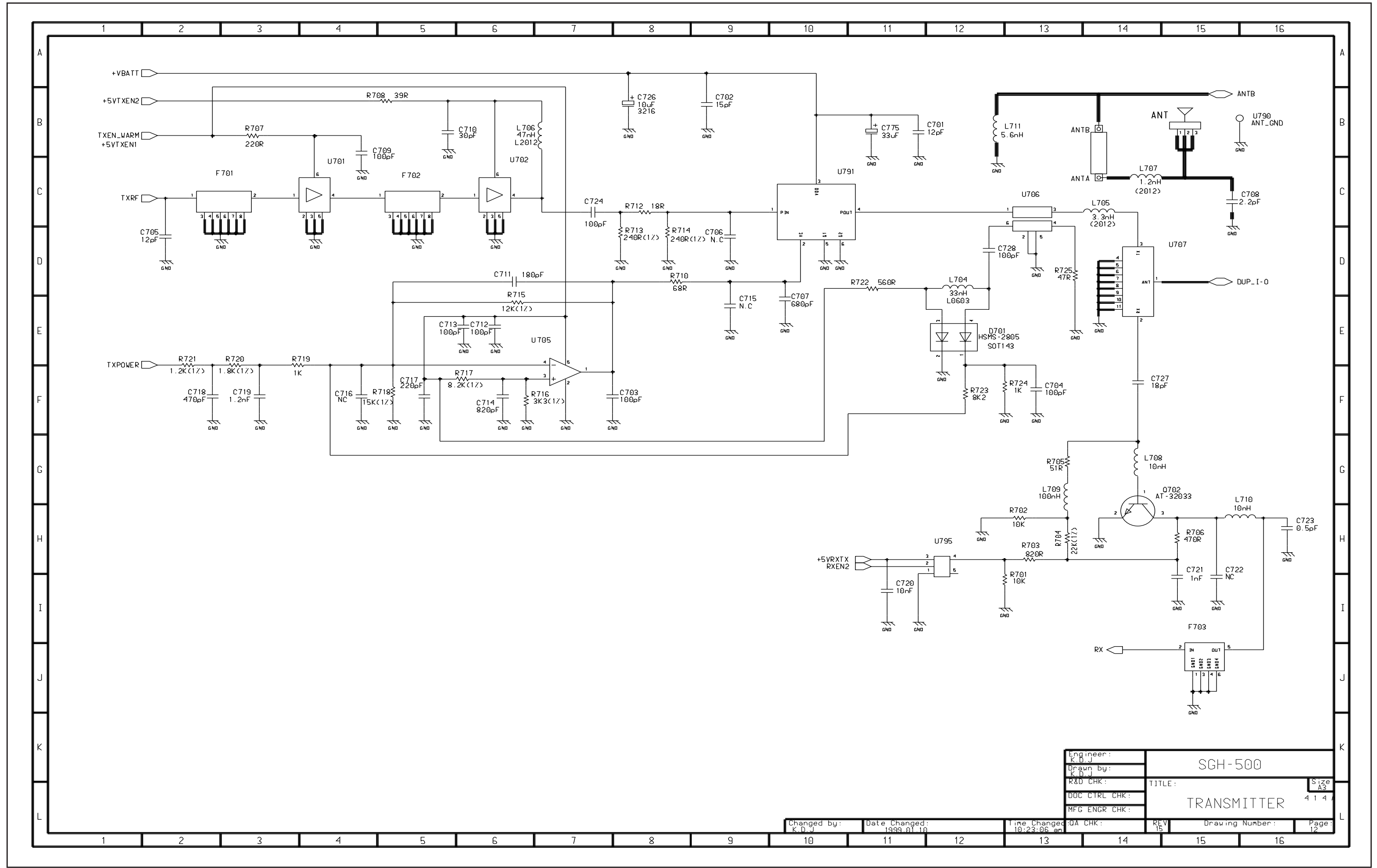

Engineer:	K.D.J		SGH-500
Drawn by:	K.D.J		
R&D CHK:			TITLE:
DOC CTRL CHK:			TRANSITTER
MFG ENGR CHK:			Size: A3
Changd by: K.D.J			4 1 4
Date Changed: 1999.01.10			Page: 12
Time Changed: 10:23:06 am			
REV: 15			Drawing Number:

5-15 Memory

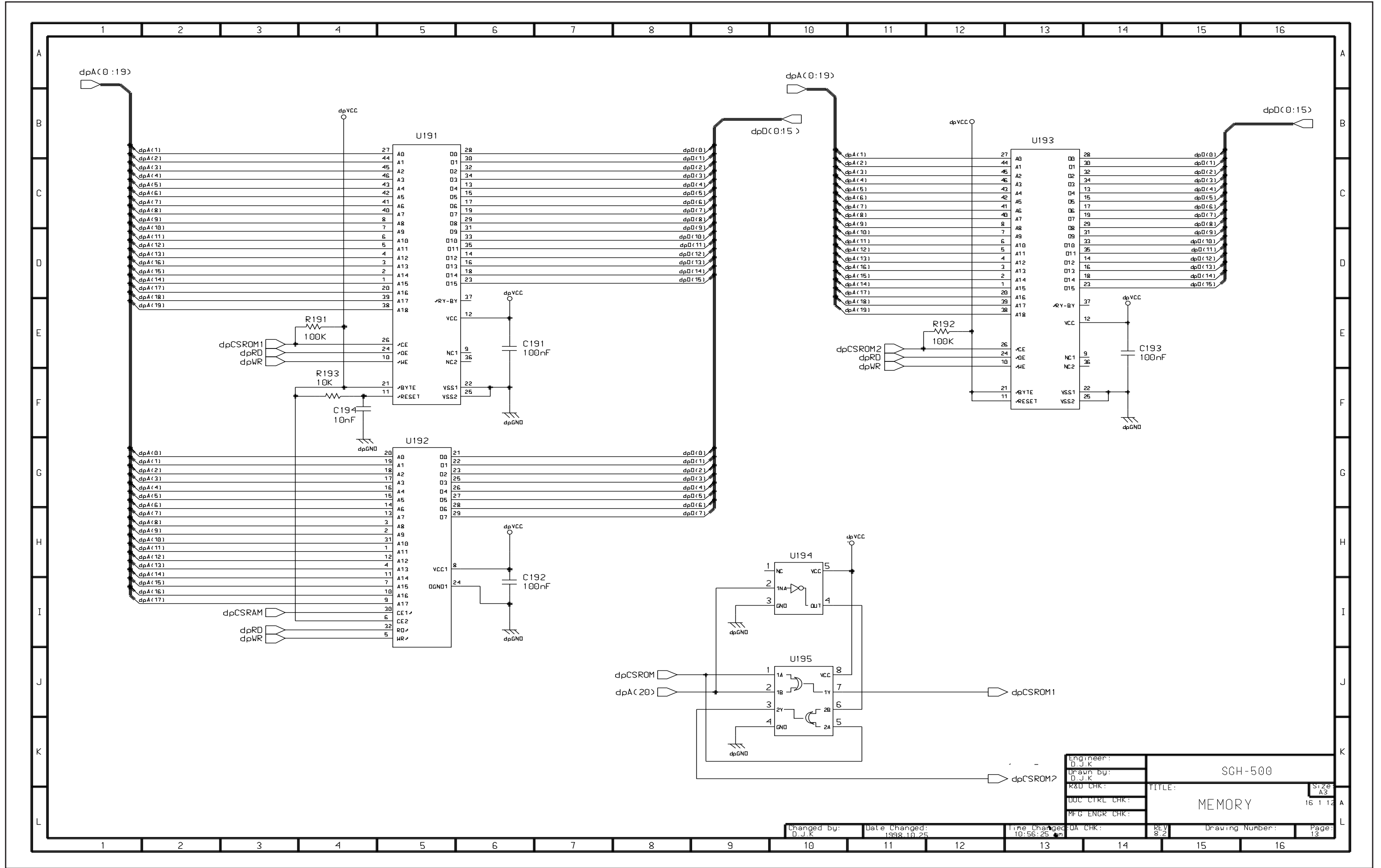

Engineer: D.J.K.	SGH-500	Size: A3
Drawn by: D.J.K.		TITLE: MEMORY
R&D CHK:		16 1 12 A
DOC CTRL CHK:		
MFG ENGR CHK:		

Changed by: D.J.K.	Date Changed: 1998.10.25	Time Changed: 10:55:25 AM	REV 8.2	Drawing Number:	Page: 13
-----------------------	-----------------------------	------------------------------	------------	-----------------	-------------